

Design of an Aperture Phased Array System for the SKA

A. J. Faulkner¹, P. Alexander², M. E. Jones³, R. Bolton², A. van Ardenne⁴, S. Torchinsky⁵

¹Jodrell Bank Observatory, The University of Manchester, Macclesfield, Cheshire, SK11 9DL, UK.
andrew.faulkner@manchester.ac.uk

²University of Cambridge, Cavendish Laboratory, Cambridge CB3 0HE, UK. pa@mrao.cam.ac.uk;
rosie@mrao.cam.ac.uk

³Astrophysics, Denys Wilkinson Building, Keble Road, Oxford, OX1 3RH, UK. mike@astro.ox.ac.uk

⁴ASTRON, P.O. Box 2– 7990 AA Dwingeloo, The Netherlands. ardenne@astron.nl

⁵Observatoire de Paris, Carte du Ciel, 61 avenue de l'Observatoire, 75014 Paris. Steve.Torchinsky@obspm.fr

Abstract

Aperture phased arrays operating up to 1 GHz are highly flexible collector systems, uniquely capable of performing an HI survey of a billion galaxies and observations of the Epoch of Reionisation, two of the Key Science Programmes for the Square Kilometer Array, SKA. Such high performance arrays are only becoming feasible in the timescales of the SKA due to technological advances in array design, low noise amplifier implementations, and increased processing and communications speed. In this paper we discuss the scientific benefits of an aperture phased array system operating from 70 MHz to 1,000 MHz, using a mixture of sparse and dense arrays and show their implementation as part of the SKA is achievable and highly desirable.

1. Introduction

A radio telescope with close to a square kilometre of collecting area used to survey red-shifted hydrogen emission to the earliest cosmological epochs has long been an aspiration of radio astronomers, see e.g. Wilkinson [1]. The preliminary specification of the Square Kilometre Array, SKA, as described by Schilizzi et al. [2], is expanded in frequency coverage and angular resolution, over the original concept, to cover many other scientific observation requirements, see Carilli et al. [3]. This instrument can be considered to be a physics instrument exploring fundamental scientific questions. High observation speed is a critical requirement for hydrogen surveys, to keep the time required to a few years. This level of SKA performance would be unaffordable if it was built as a typical radio telescope, however, the progress of high performance data processing, wide-bandwidth communications and low-noise, ambient temperature amplifiers makes the prospect of a telescope using almost entirely digital signal processing a real possibility.

The SKA Design Studies, SKADS [4], a European Community (EC) Framework Programme 6 project, has the task of producing a costed SKA design. Most of the technical work is in the development of a 300 – 1,000 MHz, aperture phased array capable of meeting the performance requirements of the SKA. While this work will evolve until the end of SKADS in June 2009, early design and cost modelling has been published (Alexander et al. [5] and Bolton et al. [6]). This shows that by using the benefits of the aperture array at a low RFI SKA site and fully integrating it with high frequency dishes, it is possible to design a practical SKA. The development of high frequency aperture arrays will continue up to the start of SKA construction in an EC programme called PrepSKA (prepare for SKA).

2. Aperture phased array background

An aperture array, AA, is a large number of small, fixed antenna elements plus receiver chains which can be arranged in a regular or random pattern on the ground. A beam is formed and steered by combining all the received signals after appropriate time delays for phase alignment, this can be repeated concurrently many times to create many simultaneous independent beams, yielding a very large total Field of View, FoV. The number of useful beams produced, and hence total FoV, is essentially limited by signal processing, data communications and computing capacity. Aperture arrays can readily operate at low frequencies with large effective areas, unlike dish based

systems, where performance falls off when the dish diameter is only a few wavelengths. AAs using substantial digital processing systems are an inherently very flexible collector technology, since the system can ‘trade’ FoV, bandwidth and number of bits per sample, consequently the performance can be matched to that required by the experiment. It is also possible to tailor the processed FoV as a function of frequency: for example, for the HI experiment an FoV increasing substantially faster than the λ^2 (as for a single feed dish) is key to obtaining a reasonable survey speed.

Inherently, there are two basic configurations of AA, close packed (dense) and sparse, which are discussed in Braun & van Cappellen [7]:

- A dense array samples the incoming wavefront at least at the Nyquist rate by having elements spaced $\leq \lambda/2$. As the frequency reduces the array oversamples the wavefront resulting in the A_{eff} remaining roughly constant. The benefit of this fully sampled system is that there can be very tight control of the beams, with no array artefacts introduced. This type of array has the highest dynamic range capability of AAs.
- A sparse array, as its name implies, has elements spaced further apart than $\lambda/2$. In the limit, each element can act independently and provide an element level A_{eff} which scales as λ^2 . This is of great benefit, particularly at frequencies below $\sim 500\text{MHz}$ where sky noise becomes dominant. The increasing A_{eff} increases the sensitivity and hence survey speed with increasing redshift (as does a single pixel feed on a dish), which helps counteract the decreasing flux density from the sources. In an interferometer such as the SKA, it is likely that a sparse array will be the preferred solution at frequencies $< 500\text{MHz}$.

3. SKA array selection

As part of a costed design, SKADS has proposed an AA system for use in the SKA. It consists of two collecting arrays: AA-lo a sparse array using wideband feeds, probably log-periodic, which operate from 70MHz to 450MHz and a dense array AA-hi which operates between 300MHz and 1GHz, close packed up to $\sim 800\text{MHz}$. Between 800MHz and 1GHz the A_{eff} falls off since the array is becoming sparse. This is to minimise the total element count and, hence, cost and power requirements.

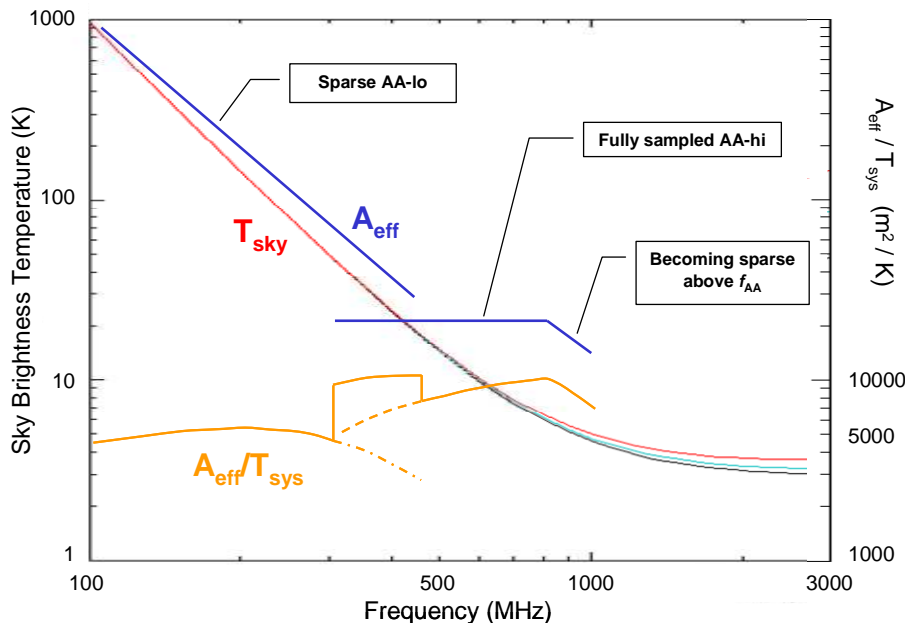

Figure 1: Characteristics of an SKA capable aperture array system

AA-hi falls as λ^2 . Both arrays can be used in the overlap frequency range from 300 – 450 MHz: this has the effect of roughly maintaining the total system sensitivity where the sky noise is starting to increase. The resulting sensitivity $A_{\text{eff}}/T_{\text{sys}}$, is shown in the bottom orange line.

The system characteristics are shown in Figure 1. The blue lines show the effective areas of the arrays. The sparse AA-lo can be seen to have increasing an A_{eff} as the frequency is reduced which is almost offsetting the increasing sky noise, T_{sky} , derived from Medellin [8], also shown in Figure 1. The AA-hi has a roughly constant A_{eff} from its lower operating frequency of 300MHz up to where the array stops Nyquist sampling the incoming signal at 800MHz. Above 800MHz the A_{eff} for

4. Scientific Rationale

A key science driver for the SKA, indeed the original concept for the SKA, is an HI survey for galaxy evolution and dark energy. This experiment detects the faint emission at 1.421 GHz from neutral hydrogen. Due to Doppler frequency shift with increasing distance requires coverage from below 1400 MHz to <500 MHz. Detecting redshifted HI becomes increasingly challenging as we move out in z to $\sim 3-4$. To complete a survey to a specified galaxy mass limit requires an increasing survey speed with increasing z . Spectral requirements and baselines for these experiments are relatively modest, this is a detection experiment in survey mode, so we only need to adequately sample the HI line to avoid confusion in position-velocity space. As discussed above this can be implemented with an AA, the survey can be completed in a matter of years, compared to decades for any other technology.

The parameter that has been largely unexplored in the radio spectrum is the time domain for short, transient signals. Ideally, we would like to monitor as much of the sky as possible for unexpected events. Whenever this has been improved before new phenomena have been discovered, e.g. pulsars. There are many configurations that could be investigated, a large FoV and relatively low sensitivity, scanning with higher sensitivity, various frequency ranges etc. The AA can uniquely be configured for these ‘exploration of the unknown’ surveys.

5. Implementation Considerations

The SKA configuration is still the subject of considerable study and simulation, however the general layout is anticipated to have about 50% of the collecting area in a concentrated core of ~ 5 km diameter and the rest of the collectors organised as stations spread logarithmically along maybe five spiral arms. The wide field collectors will have restricted maximum baselines of ~ 180 km. There is a trade-off between size and number of the arrays to give

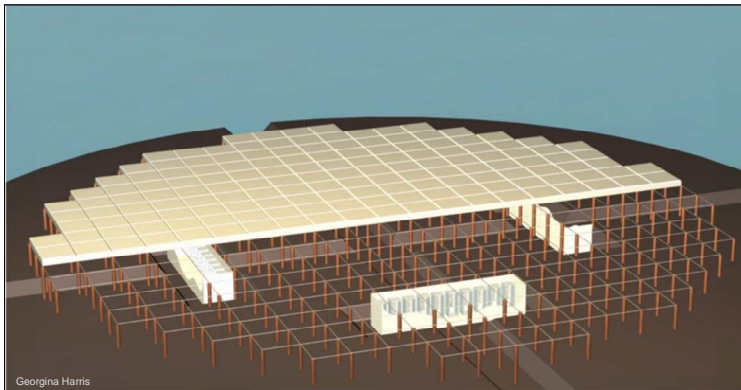

Figure 2: Cutaway of high-frequency AA

being considered: Vivaldi, Bunny Ear Comb Array, Munk-Checkerboard etc, while these designs are being optimised, we already have suitable solutions available. A major cost driver is the element spacing, currently expected to be ~ 21 cm. The receiver noise is critical to the system sensitivity. Due to the very high number of low noise amplifiers (LNAs) dispersed over a wide area, it is not considered viable to cryogenically cool them, although it will be necessary to stabilise their temperature. Hence, technologies are being explored to develop high performance, room temperature devices which can be matched over a very wide fractional bandwidth to the antenna elements. Substantial progress is being made in this area and we anticipate overall T_{sys} at 800 MHz to be ≤ 50 K for Phase 1 SKA and ≤ 37 K for Phase 2.

Figure 3 shows the outline system design of the AAs. In essence, the receiving elements are positioned as required with local matching and amplification, the received signal is then carried at baseband over copper links using commodity Category-7 (CAT7) networking cables to screened processing areas. Within the screened areas all the digitisation and beamforming is carried out. A key constraint is to keep all digital signals within their screened environments, and have only analogue signals close to the array itself. This is primarily for self-induced RFI mitigation, but it also means that the complete received signal is available to the processing system, which enables an upgrade path. Further, the complex electronics are mounted in conventional racking systems, which can be water-cooled for good temperature stability, leading to lower power requirements and improved reliability.

the total collecting area. To give excellent u-v plane coverage we anticipate using ~ 250 arrays, each AA-hi having a diameter of ~ 60 m and the AA-lo diameter of ~ 200 m.

Here we will concentrate on the design of the AA-hi, illustrated in Figure 2, which is the most critical in terms of total number of elements to be integrated and the bandwidths involved. Each array consists of 75,000 dual polarisation elements, making 150,000 receiver chains. The design of the elements and the details of the overall array are the subject of ongoing research. There are a number of different element types

The processing is in a two stage structure, the first stage processors perform the initial digitisation and beamforming on ‘tiles’ of 256 dual polarisation elements, the number of beams, their frequencies plus bandwidth and bits per sample can be configured at the observation time. The constraint is the total data rate of the internal digital links. Identical beams from all the tiles in each array are then combined in the ‘Station Processors’ to produce the required station beams. To achieve the total FoV needed there are many hundreds of individual station beams.

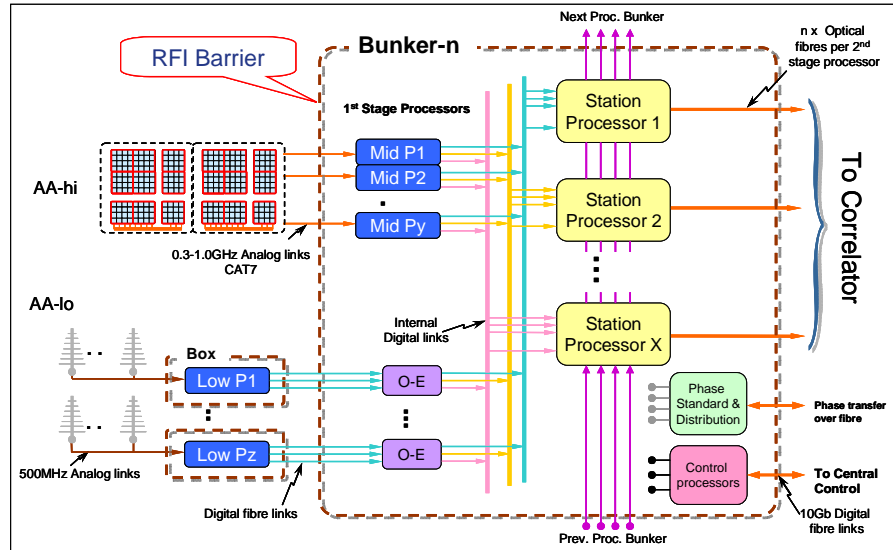

Figure 3: AA system diagram

Every first stage processor has a link to all the Station Processors. The Station Processors each link to wide area communication fibres directly to the central correlator. Again, the overall array performance is constrained by the total bandwidth to the correlator, which can be flexibly allocated for an observation. The signal processing, which will be using integer arithmetic for efficiency in power and silicon, requires a capability estimated for an AA-hi array of ~ 10 PetaMACs (10^{16} multiply-accumulate instructions per second). It has become clear that this performance level is achievable for the start of SKA Phase 1 in 2012 using either a dedicated ASIC solution, or massively multi-core integer processors. This latter processing solution is very attractive for flexibility and the implementation of novel algorithms.

Very high dynamic range observations are essential to the SKA. This AA implementation gives an unblocked aperture with a very flexible processing system capable of applying arbitrarily accurate and fine calibration adjustments. The research is into measuring the required coefficients and uniquely the AA can continuously observe multiple astronomical calibration sources during observations for on-line adjustments.

6. Conclusions

Using the base of rapidly advancing digitisation and processing technologies and improving the other components required, the design and build of a very high performance aperture array system can be realistically be achieved in the timescale of the SKA. The availability of SKA-performance aperture arrays will enable important scientific experiments to be carried out which will lead to significant discoveries in fundamental physics.

7. References

1. P.Wilkinson, "The Hydrogen Array" IAU Colloquium 131, ASP Conference Series, Vol. 19, 1991, T.J. Cornwell and R.A. Perley (eds.), pages 428-432
2. Schilizzi R. et al., "Preliminary Specifications for the Square Kilometre Array", 2007, www.skatelescope.org
3. Carilli C. et al., "Science with the Square Kilometre Array", New Astronomy Reviews, Vol.48, Elsevier, December 2004
4. "Square Kilometre Array Design Studies, SKADS", www.skads-eu.org
5. Alexander P. et al., "SKA Memo 93: SKADS Benchmark Scenario Design and Costing", 2007, www.skatelescope.org
6. Bolton, R. et al., "SKADS Benchmark Scenario Design and Costing - 2", in press
7. Braun R. & Cappellen W. , "SKA Memo 86: Aperture Arrays for the SKA: Dense or Sparse?", 2006, www.skatelescope.org
8. Medellin G.C. "SKA Memo 95: Antenna Noise Temperature Calculation", 2007, www.skatelescope.org